

Mini Meg™ Pocket Megohmmeter Operation and Maintenance



Made in America



Figure 1. 94055 Mini Meg Pocket Megohmmeter

Description

The SPI Westek 94055 Mini Meg Pocket Megohmmeter is a portable test instrument designed for measuring both surface and surface-to-ground resistance of static dissipative and conductive materials. Seven color-coded LEDs, read from right to left, easily identify static dissipative and conductive ranges. The Mini Meg will test materials with surface resistivity of 1×10^5 to 1×10^{10} . This test instrument is ideally suited for Quality Control and Field Service personnel as well as for use in routine auditing of your ESD protective materials. The Mini Meg features simple one-button operation and a 9V battery for ease of use and maximum portability. This auto-ranging instrument weighs only six ounces. The high-impact plastic case ensures durability despite the meter's light weight.

The Mini Meg has not been designed to meet ESD S4.1 test equipment requirements and therefore measurements obtained with this device may not agree with measurements taken according to the ESD S4.1 test procedure. This test instrument is intended for use only as an auxiliary tool for monitoring surface resistance performance.

If you are interested in obtaining a meter which does meet all the test equipment requirements of ESD S4.1, we recommend our model 94057 Surface Resistance Test Kit. For more information on this product ask for Technical Bulletin TB-5515.

Installation

Remove the meter from the carton and inspect for damage. Each unit should be fully charged and includes:

- 1 Mini Meg Pocket Megohmmeter
- 1 Surface-to-Ground, cord assembly
- 1 Installed 9V battery

Properly store the megohmmeter and its component assemblies when not in use.

Operation

The Mini Meg will perform Surface Resistivity and Surface-to-Ground resistance measurements. Work surfaces and materials to be tested should be cleaned prior to testing to ensure that surface dirt and contamination do not affect results. It is recommended that non-silicone and non-alcohol based cleaners such as SPI Westek's Resque 2 Surface and Mat Cleaner be used for regular cleaning of ESD protective work surfaces. When non-ESD surfaces are being used, Resque 2 Topical Antistat is recommended for eliminating static charge generation.

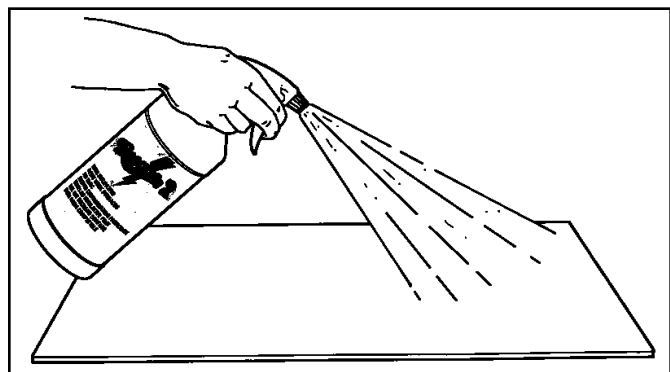

Figure 2. Cleaning the work surface before testing.

Surface and Surface-to-Ground resistance readings are indicated by the series of LEDs on the face of the meter. The LEDs are read from right to left as follows:

- 1. RED – $>10^{10}$, Meter is on and battery is functioning
- 2. RED – Less than 1×10^{10}
- 3. GREEN – Less than 1×10^9
- 4. GREEN – Less than 1×10^8
- 5. GREEN – Less than 1×10^7
- 6. YELLOW – Less than 1×10^6
- 7. YELLOW – Less than 1×10^5

Each LED indicates one order of magnitude of resistance. If the test surface is conductive to less than 10^5 , all the LEDs will be lit. If it is neither conductive nor static dissipative, only the red "On" LED will be lit.

Surface Resistivity Measurements

Surface resistivity measurements are made using only the meter without the cord assembly. When the white button is depressed a test voltage of 9 VDC is applied to the meter's center electrode. The second resistivity electrode will supply the resistance bridge and provide the measurement. To perform surface resistivity tests, follow these simple instructions:

- A. Check battery operation by depressing the white button on the center of the megohmmeter. The red "On" lamp at the far right should light to indicate that the unit is functioning properly.
- B. Place the meter on the surface being tested. All three electrodes should make contact with the surface.
- C. Press the white button. The surface resistance will be indicated by the number of LEDs which light up. The more lights illuminated, the greater the conductivity of the surface. The measurement is in ohms/square.

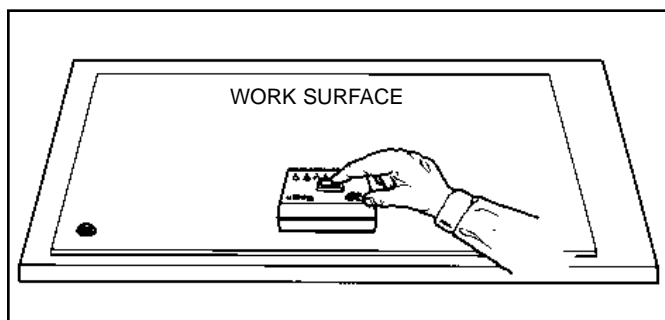

Figure 3. Measuring surface resistivity.

Surface-to-Ground Measurements (RTG)

The Surface-to-Ground feature is best used when expected results are less than 10^6 ohms, and when residual voltages can be removed from the test surface. Residual voltages may cause the two upper range LEDs to light, resulting in a false reading.

When the Surface-to-Ground cord is plugged in, voltage is diverted from the center electrode to the cord in order to measure resistance. When making Surface-to-Ground tests, follow these procedures:

A. Check battery operation by depressing the white button. The red "On" lamp will indicate that the unit is functioning properly.

B. Plug the Surface-to-Ground cord into the left side of the megohmmeter.

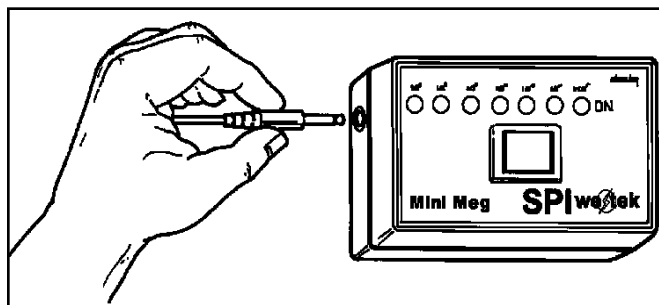

Figure 4. Installing Surface-to-Ground cord assembly.

- C. Place the Mini Meg on the test surface.
- D. Connect the test cord to the ground-point for the surface.
- E. Press the white button. The LEDs will indicate the test results. The measurement is in ohms.

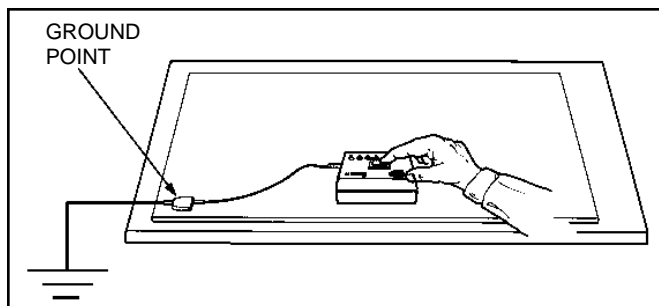

Figure 5. Measuring Surface-to-Ground resistance.

F. Unplug the cord when testing is finished.

Battery Operation

Battery function is automatically checked by the unit when the meter is turned on. If the battery voltage drops below 8 VDC, the red LED on the far right of the meter will not light, indicating a "low battery" condition. Replace battery with a new 9V alkaline battery.

Maintenance

Your Mini Meg will require very little maintenance, and there are few user-serviceable parts. If your meter requires service beyond the simple procedures described below please contact the factory.

Electrode Cleaning

To assure accurate measurements the electrodes should be kept as clean as possible. A thorough cleaning at least every 3 months is recommended. The following is the recommended cleaning procedure:

1. Carefully remove the electrodes from their snap-jacks using a screw driver or other blunt flat bladed object. Avoid scratching or bending electrodes.

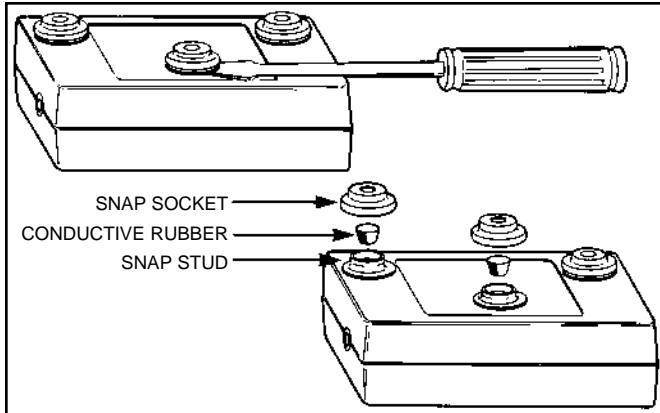

Figure 6. Cleaning the electrodes.

2. Clean both the snap stud and the electrodes with a cotton swab soaked in isopropyl alcohol. Check the rubber centers for wear - the rubber should form a convex spot on the bottom of the electrode. The three electrodes will be checked with each annual, factory calibration. If electrode replacement is recommended, the customer will be notified with estimated charges before any changes are made.

Theory of Operation

The Mini Meg measures resistance by setting up a bridge between two precision 1% resistors of known value and the surface tested, of unknown value. When the white button is depressed a test voltage of 9 VDC is applied to the megohmmeter's center electrode or ground cord, depending on the test being performed. One of the bottom electrodes on the outside of the meter supplies the resistance bridge. The test voltage resulting from the bridge is compared to reference voltages established by six trimming potentiometers. Two integrated circuits are configured as comparators to check the voltage from the bridge against the potentiometers. Based on the setting of each potentiometer, the appropriate LED is lit.

Specifications

Sensitivity Range

Surface Resistivity	Less than 10^{10} ohms/sq
Surface-to-Ground	Less than 10^9 ohms

LED Key (from right to left)

1. Red	$>10^{10}$, Meter On, and Battery OK
2. Green	$<10^{10}$ Static Dissipative
3. Green	$<10^9$ Static Dissipative
4. Green	$<10^8$ Static Dissipative
5. Green	$<10^7$ Static Dissipative
6. Yellow	$<10^6$
7. Yellow	$>10^5$ Conductive

Test Sample Size 3" x 1-1/2" or larger

General Characteristics

Power Supply	9 volt alkaline battery (included)
Test Voltage	Nominal 9 volts
Electrodes	Steel and conductive rubber

Temperature Range

Operating	40°F to 120°F (10°C to 40°C)
Storage	42°F to 110°F (-15°C to +60°C)

Relative Humidity

0% to 99% (non condensing)

Operation

Resistance bridge

Readout

Seven LEDs

Resolution

One order of magnitude

Accuracy

$\pm 10\%$ all, except $\pm 20\%$ 10^9 , 10^{10}

Repeatability

$\pm 3\%$

Weight

6 ounces

Dimensions

4" x 2.5" x 1.75"

Calibration

The Mini Meg is calibrated to NIST traceable standards. It may be returned to the factory for calibration. Contact our Customer Service Department at 909-664-9986 for a Return Material Authorization. Written Purchase Orders are required for calibration services.

A check on the function of the Mini Meg can be performed with the following procedure. You will need 1% resistors of the following values: 100K, 1M, 10M, 100M, 1G and 10G ohms. These precision resistors will be placed across the two electrodes on the bottom of the meter (see Figure 7).

A. Place the Mini Meg on an insulator (e.g. Teflon or glass) and press the white test button. Only the first red LED on the right, marked "On" should be illuminated. If this LED fails to light, the battery should be replaced before proceeding.

B. Place the 10G ohm resistor across the middle electrode and the side electrode as illustrated in Figure 7. Press the test button. The second LED should light. Be sure not to contact the leads or the buttons as your body's resistance will affect the readings.

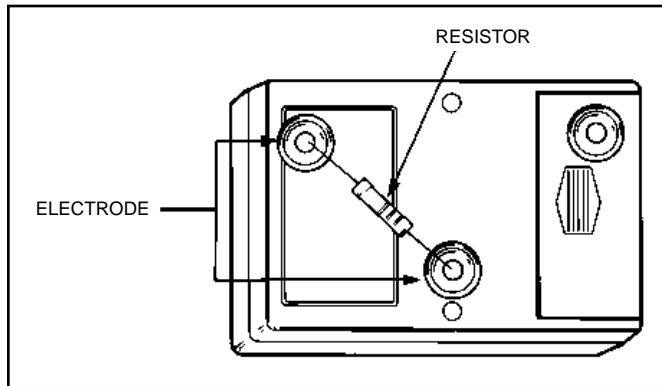

Figure 7. Calibration of the Mini Meg

C. Continue this process with each consecutive resistor, checking to make sure the appropriate LEDs are illuminated. If all resistors check properly, the unit's calibration is verified.

Adjustment

Unauthorized servicing or modifications to the Mini Meg will void the product warranty. Servicing should only be performed by the factory. See warranty section for repair charges.

Limited Warranty

SPI Westek expressly warrants that for a period of one (1) year from the date of purchase, SPI Westek Mini Megs will be free of defects in material (parts) and workmanship (labor). Within the warranty period, a unit will be tested, repaired or replaced at SPI Westek's option, free of charge. Call Customer Service at 909-664-9986 for a Return Material Authorization (RMA) and proper shipping instructions and address. Include a copy of your original packing slip, invoice, or other proof of date of purchase. Any unit under warranty should be shipped prepaid to the SPI Westek factory. Warranty replacements will take approximately two weeks.

If your unit is out of warranty call Customer Service at 909-664-9986 for a Return Material Authorization (RMA) and proper shipping instructions and address. SPI Westek will quote repair charges necessary to bring your unit up to factory standards.

Warranty Exclusions

THE FOREGOING EXPRESS WARRANTY IS MADE IN LIEU OF ALL OTHER PRODUCT WARRANTIES, EXPRESSED AND IMPLIED, INCLUDING MERCHANTABILITY AND FITNESS FOR A PARTICULAR PURPOSE WHICH ARE SPECIFICALLY DISCLAIMED. The express warranty will not apply to defects or damage due to accidents, neglect, misuse, alterations, operator error, or failure to properly maintain, clean or repair products.

Limit of Liability

In no event will SPI Westek or any seller be responsible or liable for any injury, loss or damage, direct or consequential, arising out of the use of or the inability to use the product. Before using, users shall determine the suitability of the product for their intended use, and users assume all risk and liability whatsoever in connection therewith.